

# Adjustable Aluminum Tailgate Stop Installation Instructions

Part number: 11238.11

---

**“STOP”**: Carefully read instruction sheet before installing.

1. Before installing the tailgate stop place in the location shown below to make sure the part does not interfere with any other stock or aftermarket item on your vehicle. If you do find a conflict the tailgate stop can be located at the alternative position at the lower corner of the tailgate.

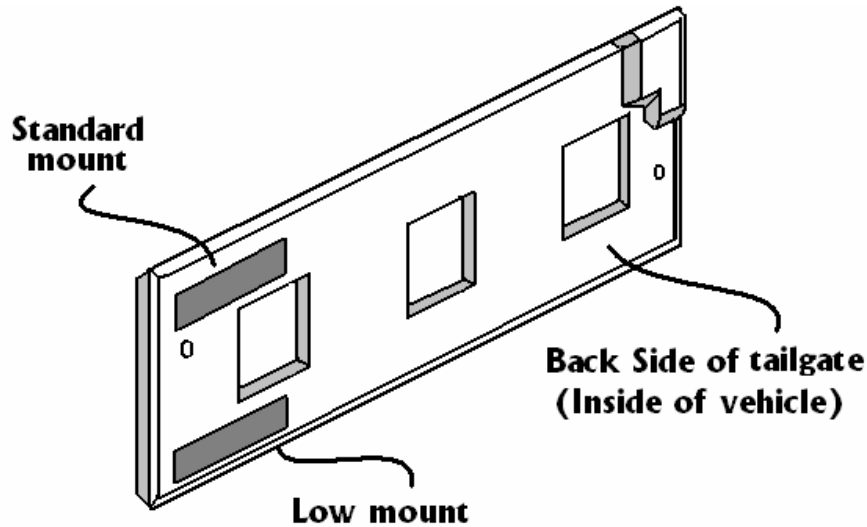

2. Locate the assembly on the rear gate using the diagram provided. All measurement points are from the outer edges of the tailgate. It is important to make sure placement is correct or there could be interference with support ribbing inside of the tailgate.

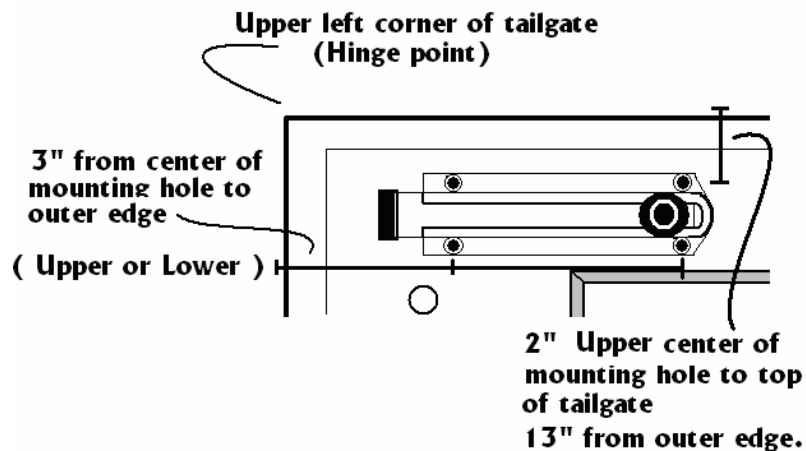

3. Mark the (4) mounting holes using the base plate as a template, and drill out with ½” drill bit.
4. Loosely preassemble the rubber lock nuts to slider base with supplied bolts. Make sure that the lip of the rubber lock nut is positioned outward towards the base of the slider. With rubber lock nuts in place position the slider over the predrilled mounting holes and push rubber lock nuts into holes.

**NOTE:** the rubber lock nuts are designed to compress as they are tightened. This will lock the slider into place.

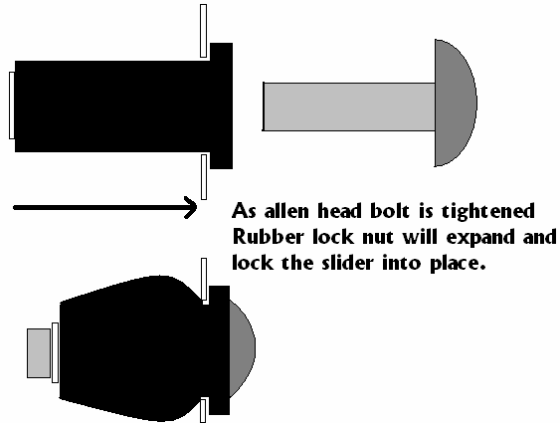

5. Tighten rubber lock bolts evenly to secure the Tailgate Stop to rear gate.

Parts List: **(1) Tailgate stop**  
**(4) Rubber lock nuts**  
**(4) Allen head lock bolts**



**Always try to use this product at a 90 degree open position. This allows for the proper positioning of the lock rod to be tightened under the slider rack at the notched location.**